

63220

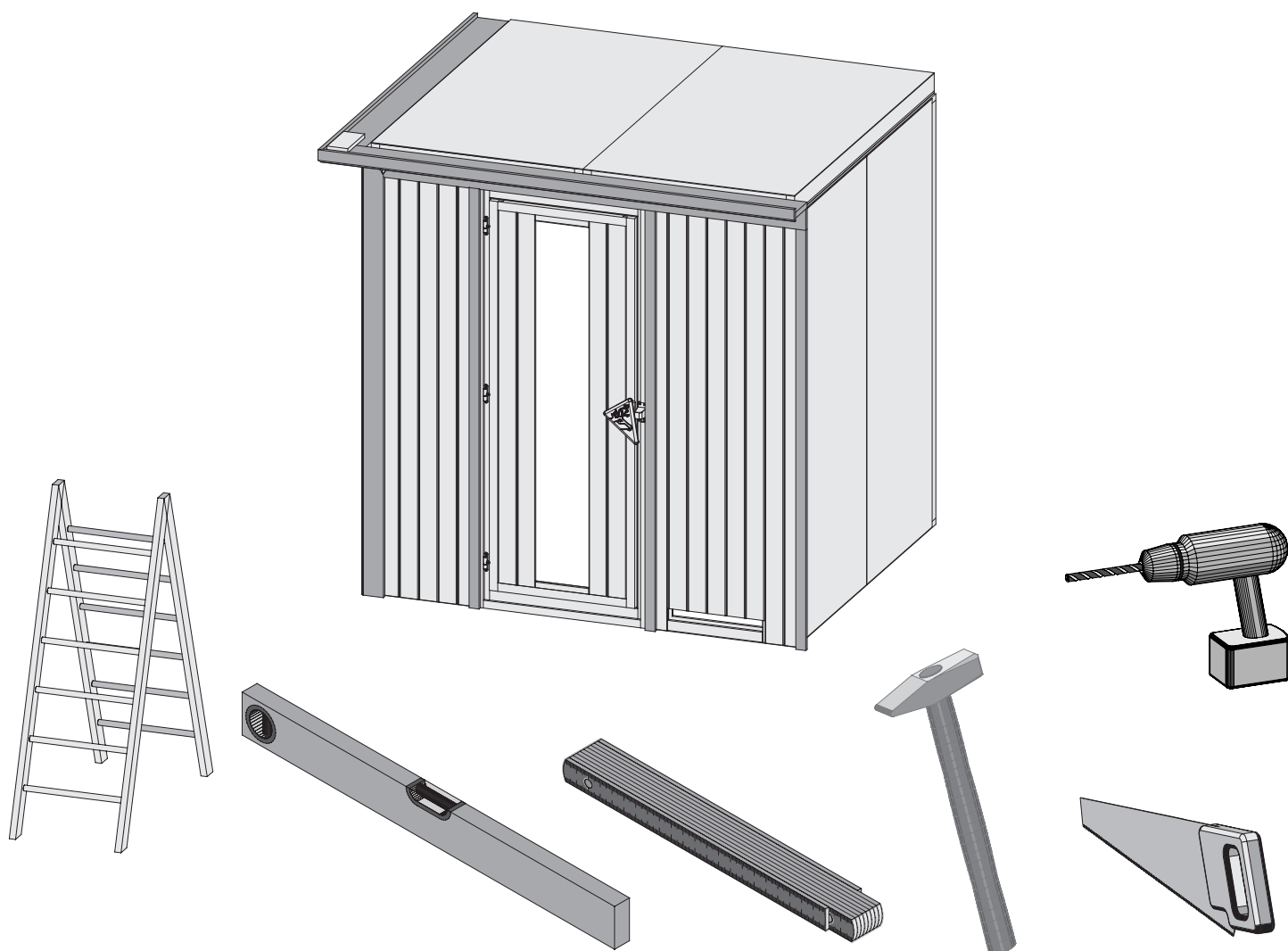

 **Aufbauanleitung**

 **notice de montage**

 **Building Instructions**

 **montagehandleiding**

 **Instrucciones de construcción**

 **Istruzioni per il montaggio**

 **Montážní návod**

 **Service-Hotline: +49 421 38693 33**



Vergleichen Sie zuerst die Materialliste mit Ihrem Paketinhalt! Bitte haben Sie Verständnis, dass Beanstandungen nur im nicht aufgebauten Zustand bearbeitet werden können!



Commencez par comparer la liste du matériel avec le contenu de votre paquet! Sachez que nous traitons uniquement les réclamations concernant le matériel à l'état non monté!



First compare the list of materials with your package contents! Please understand that complaints can be processed in the non-built status only!



Vergelijk eerst de lijst van materialen met de inhoud van uw pakket! Reclamaties kunnen alleen in behandeling worden genomen zolang de onderdelen nog niet zijn gemonteerd!



En primer lugar, compare la lista de material con el contenido del paquete. Rogamos entienda que las reclamaciones sólo pueden ser tramitadas antes de montar el objeto!



Confrontate questa distinta materiali prima con il contenuto del pacchetto! Vi preghiamo di comprendere che eventuali reclami possono essere accolti solo prima del montaggio!



63220

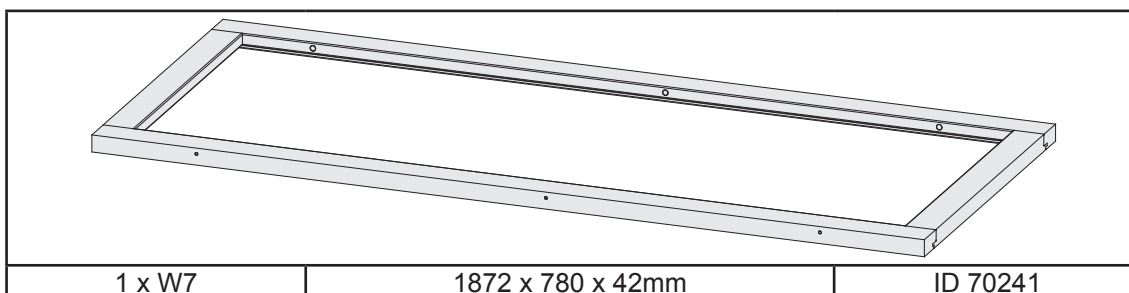
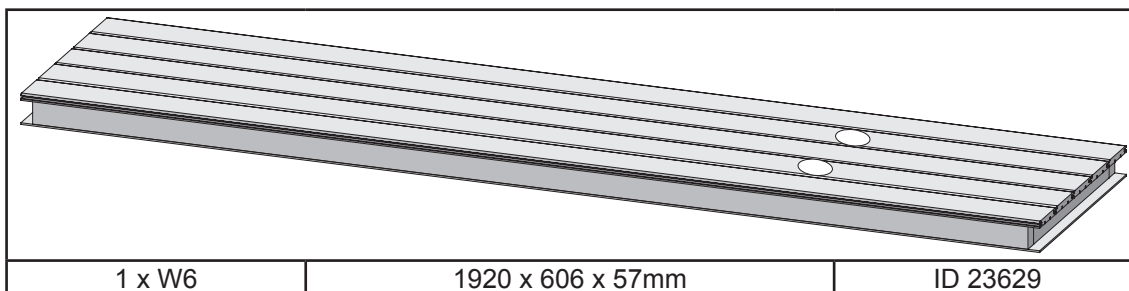
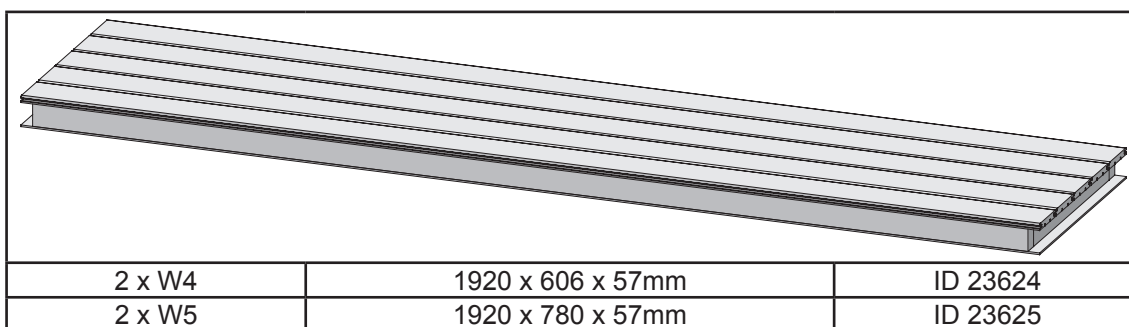
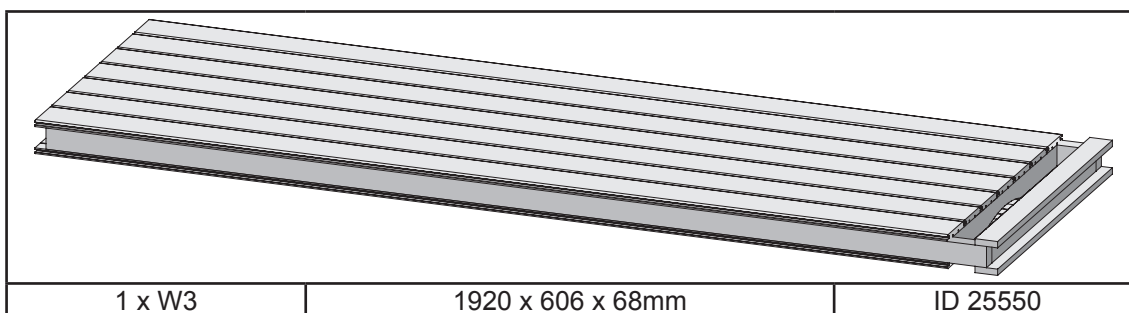
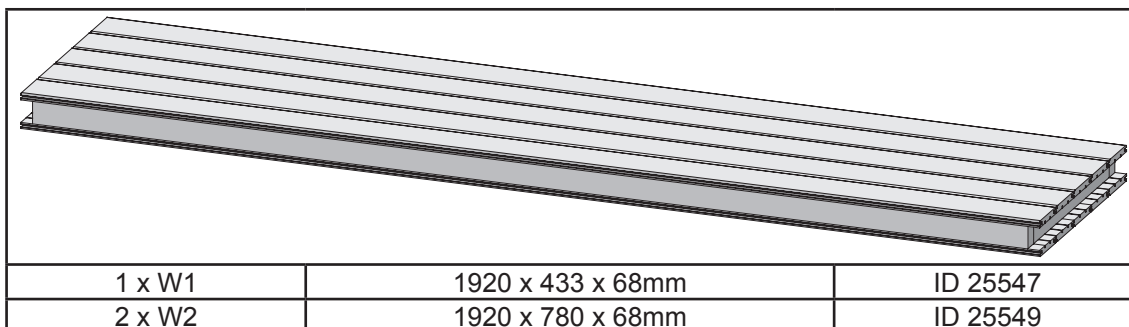

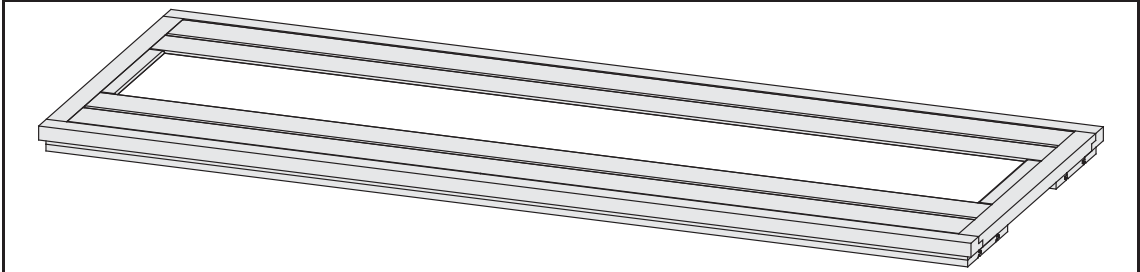

1 x W8

1747 x 656 x 36mm

ID 64238

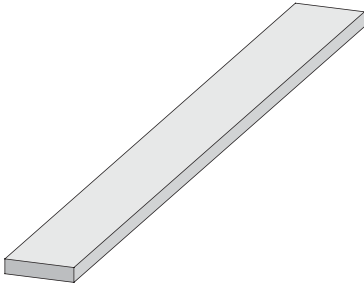

5 x B1	1920 x 19 x 3mm	ID 20799
4 x B2	750 x 36 x 12mm	ID 24239
4 x B3	1920 x 36 x 12mm	ID 24846
5 x B4	1884 x 45 x 17mm	ID 48037
4 x B5	70 x 45 x 18mm	ID 26366
4 x B6	800 x 45 x 18mm	ID 24796
4 x B7	480 x 95 x 18mm	ID 20930
4 x B8	580 x 95 x 18mm	ID 16708
2 x B9	1895 x 95 x 18mm	ID 39324
1 x B10	300 x 120 x 18mm	ID 22467
2 x B11	590 x 42 x 28mm	ID 26360
2 x B12	1130 x 42 x 28mm	ID 26361
2 x B13	1555 x 42 x 28mm	ID 24130
4 x B14	1666 x 42 x 28mm	ID 26377
2 x B15	1756 x 42 x 28mm	ID 24131
4 x B16	1841 x 42 x 28mm	ID 26376
3 x B17	1874 x 52 x 52mm	ID 26165

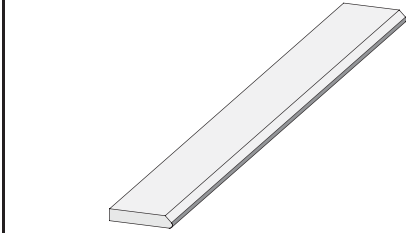

2 x G1 | 1980 x 95 x 17mm | ID 48540

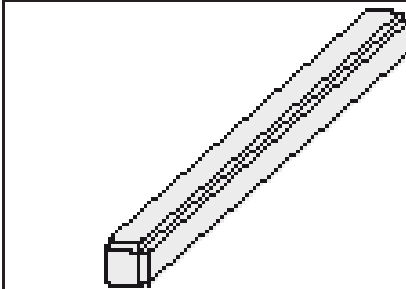

1 x K1 | 1874 x 64 x 64mm | ID 24725

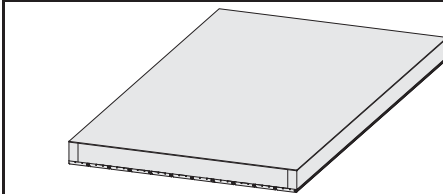

2 x M1 | 1665 x 955 x 94mm | ID 64246



40 x	4 x 30mm	ID 3686
50 x	4 x 50mm	ID 3688
30 x	4 x 70mm	ID 3689
40 x	4,5 x 80mm	ID 9204
20 x	6 x 60mm	ID 14014



2 x	4,5 x 30mm	ID 26115
80 x	4,5 x 40mm	ID 26285

6 x S1		ID 14266
--------	---	----------

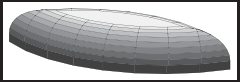

82 x S2	4,5 x 30mm	ID 26116
6 x S3	12 x 18mm	ID 46403

4 x T1		ID 26272
--------	---	----------

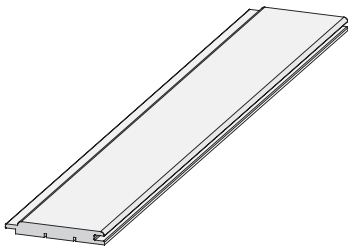

2 x E1 | 1920 x 97 x 12mm | ID 22863

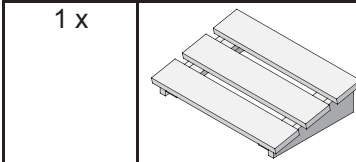

1 x | ID 25545

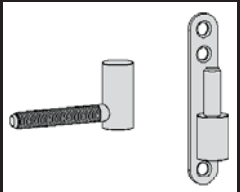
3 x		ID 3717
-----	---	---------

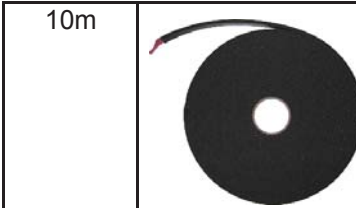

10m | ID 64208

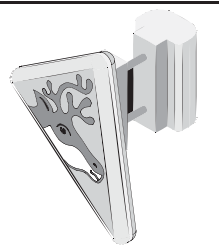
1 x		ID 26114
-----	---	----------

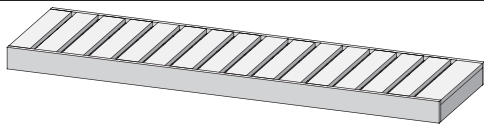

2 x L1 | 1810 x 550 x 90mm | ID 21767

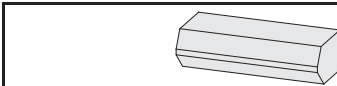

1 x Z1 | 28 x 42 x 100mm | ID 64800

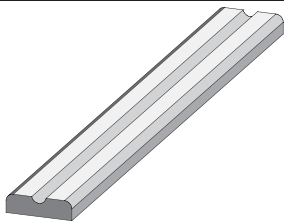

2 x L2 | 1810 x 90 x 22mm | ID 26112

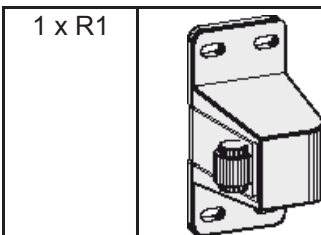

1 x R1 | ID 64245

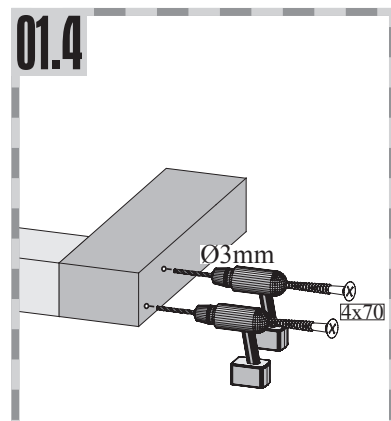
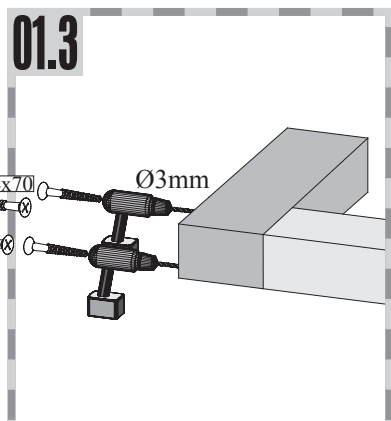
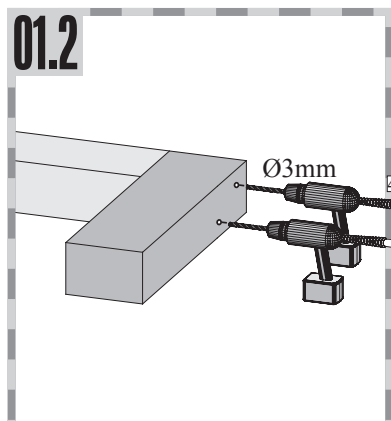
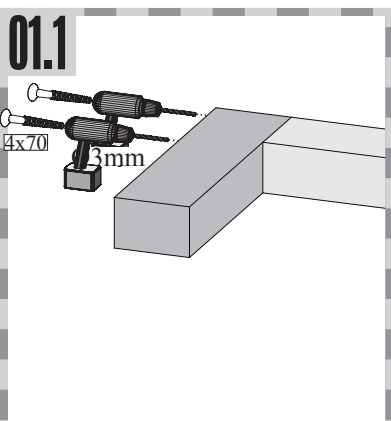
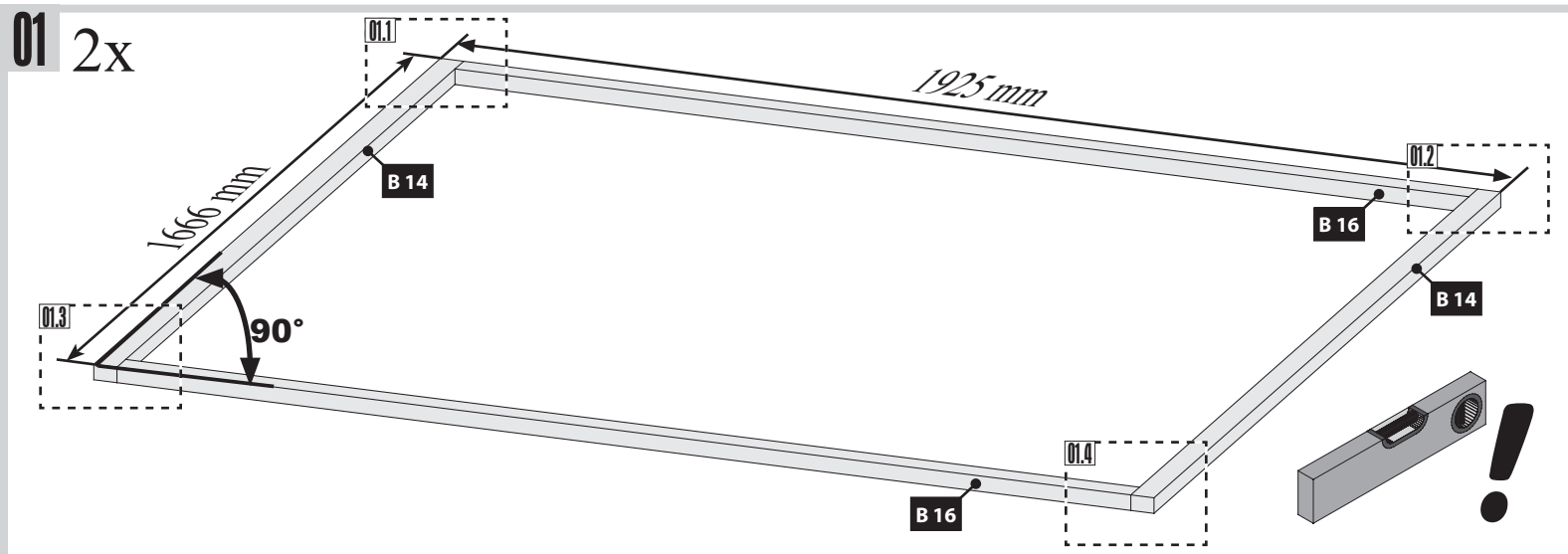
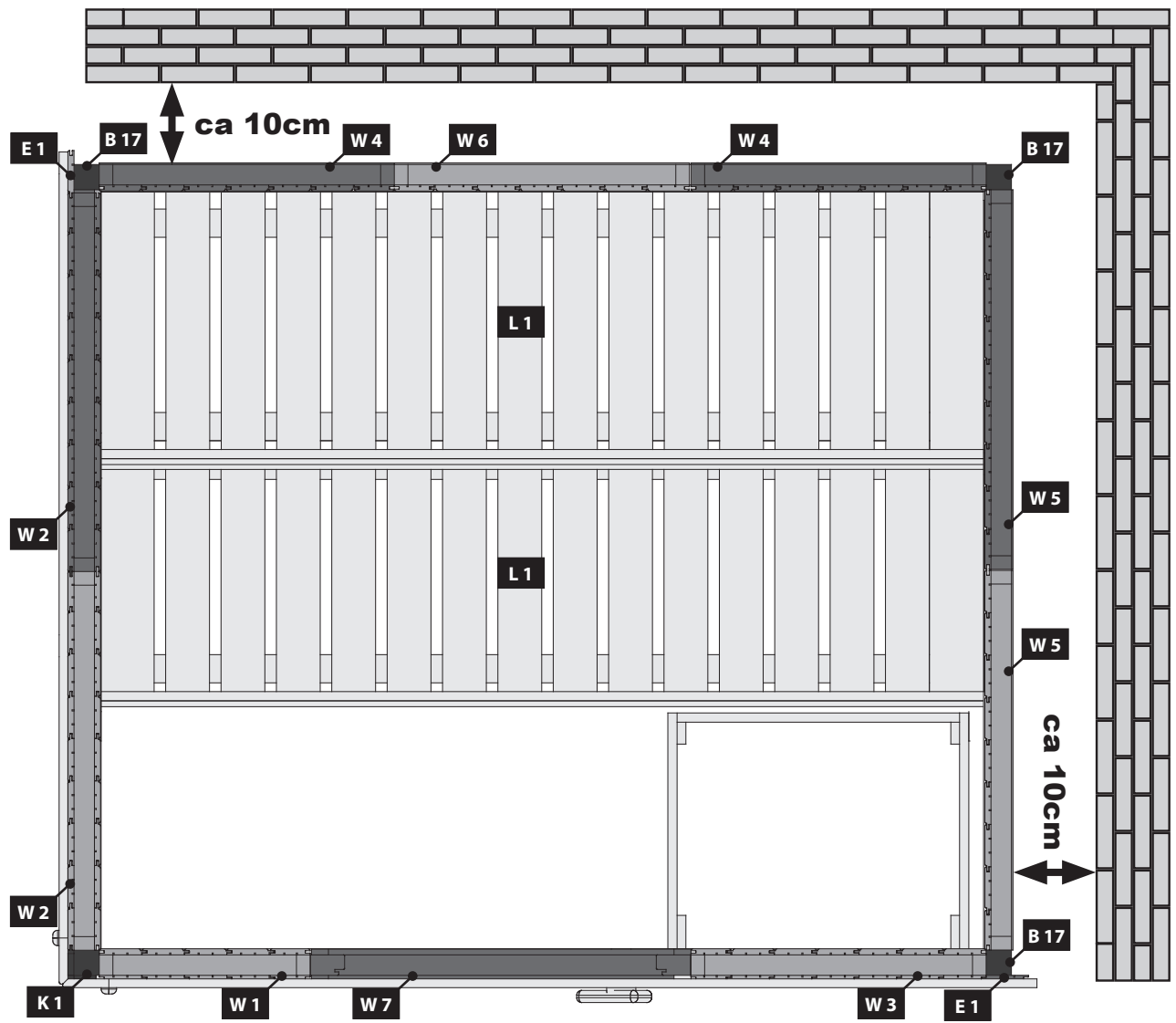

02

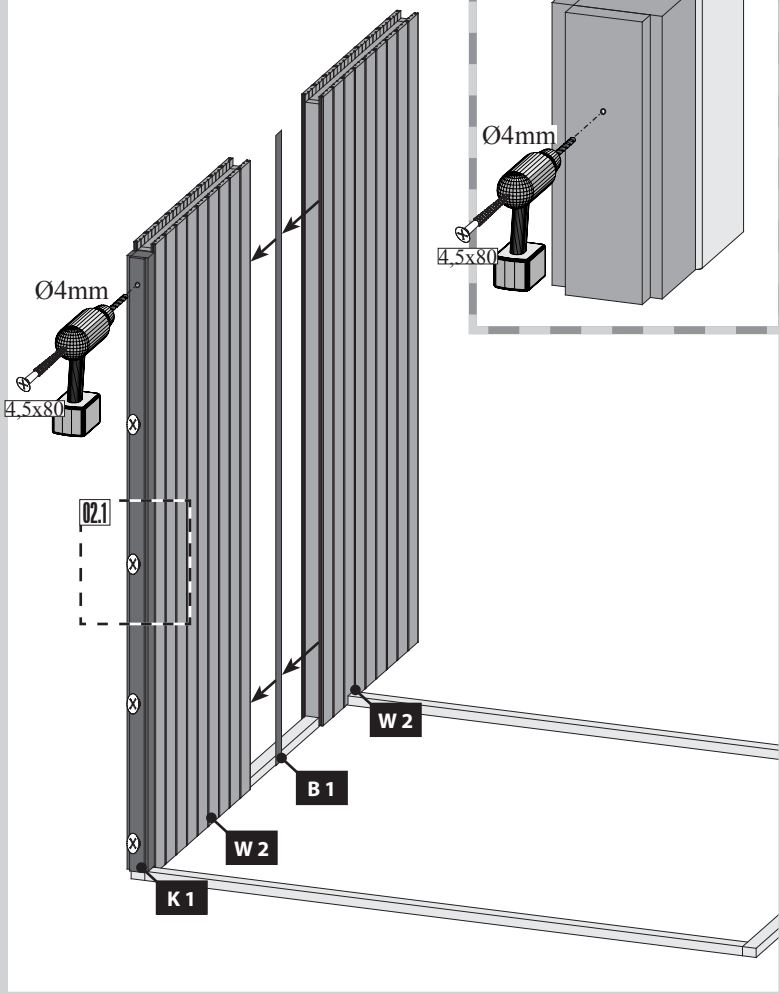

02.1

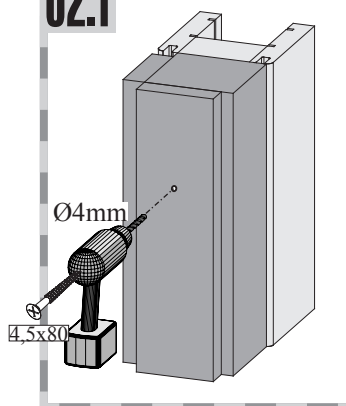

03

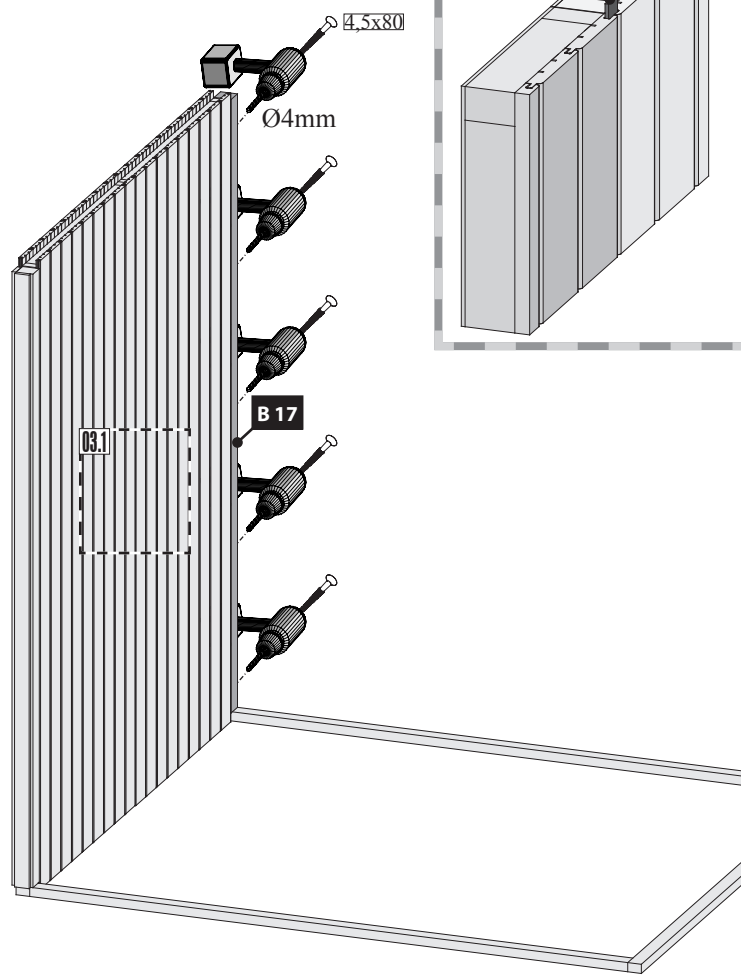

03.1

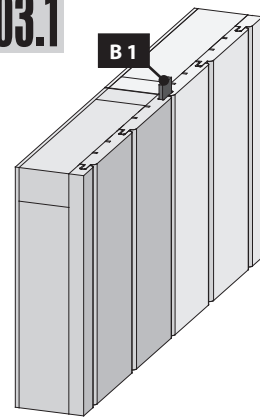

04

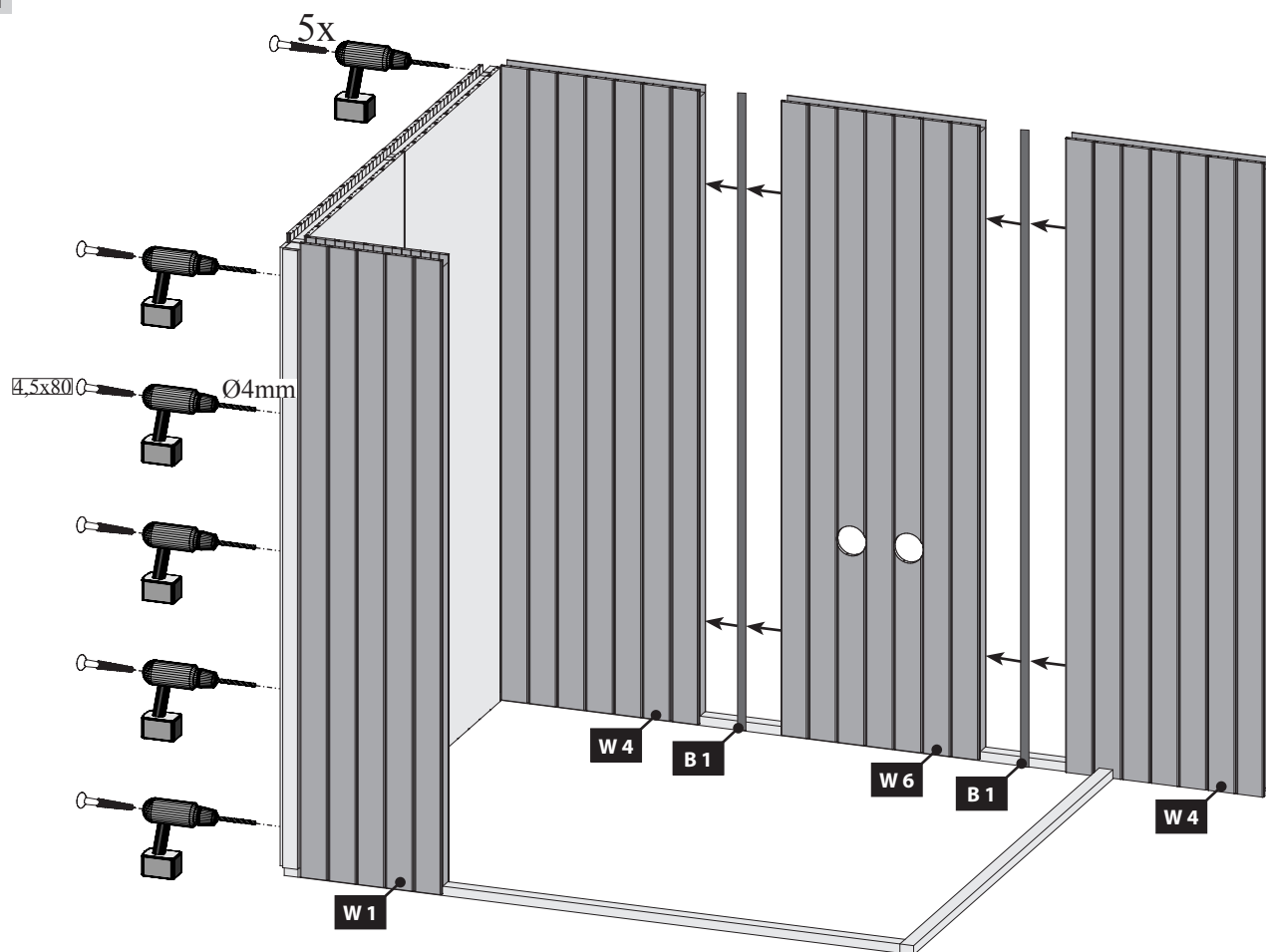

05

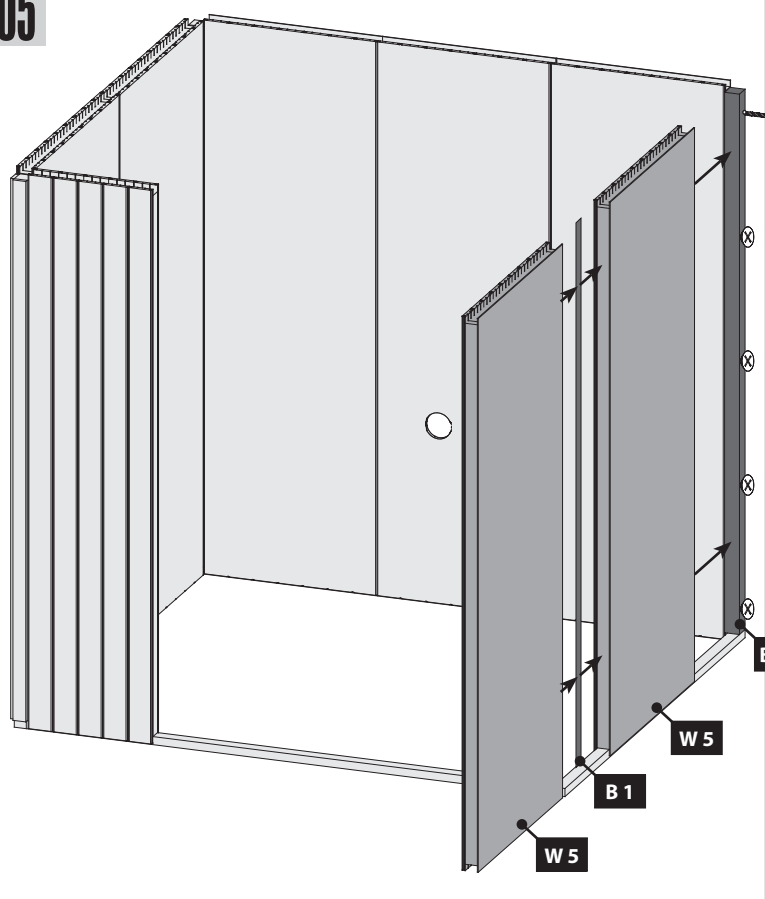

06

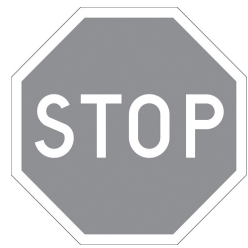
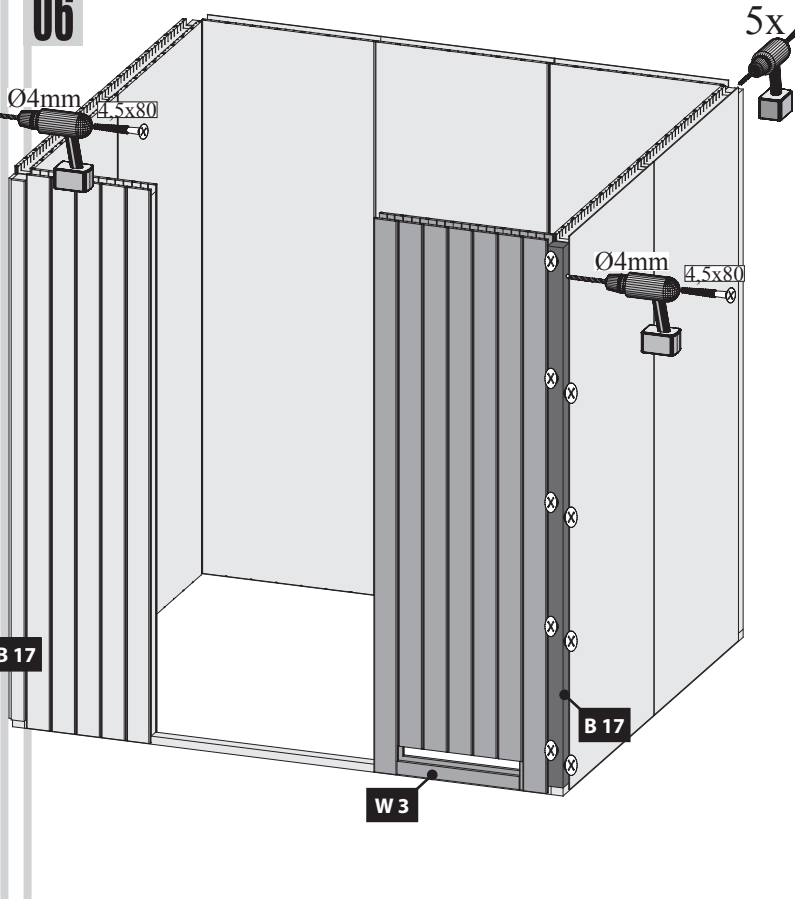

- Einbau Glastür**
- Installation of glass door**
- Montaje de la puerta de cristal**
- Montage porte en verre**
- Montage van de glazen deur**
- Installazione portello di vetro**

!!! 01 — 04 !!!

07

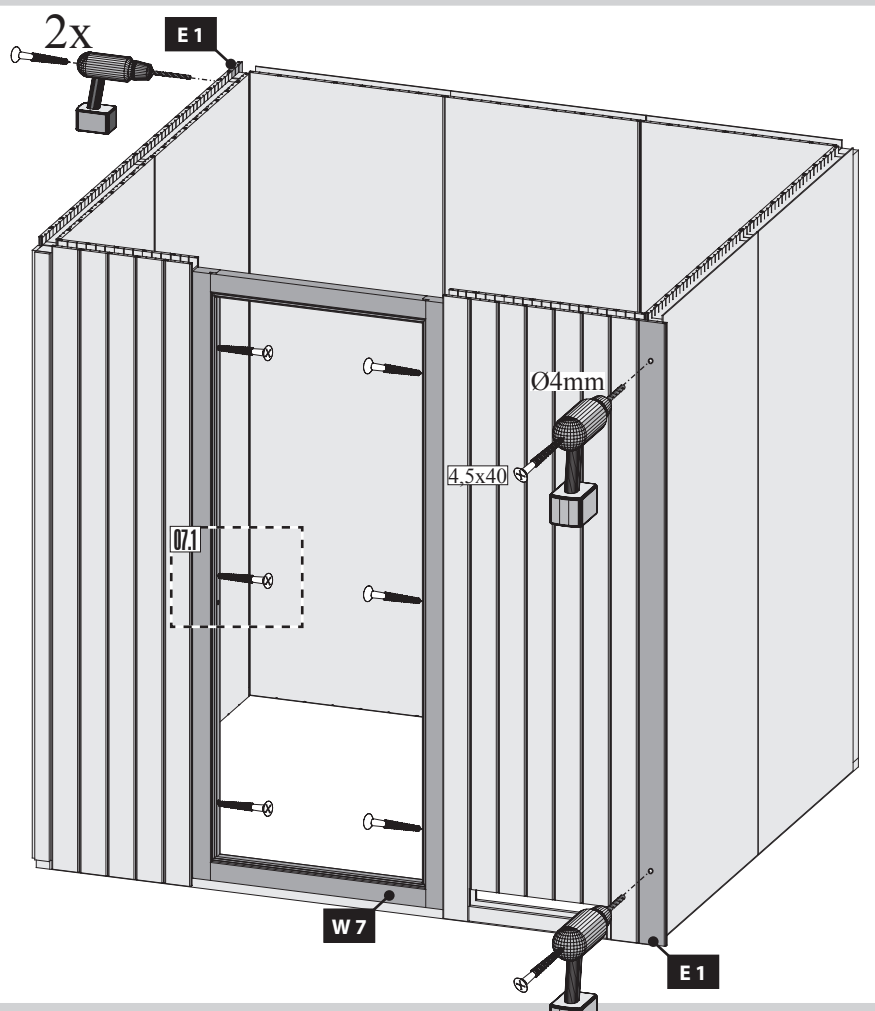

07.1-1

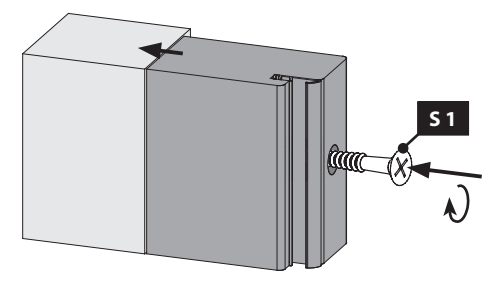

07.1-2

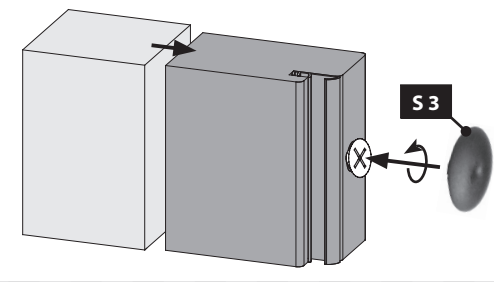

08

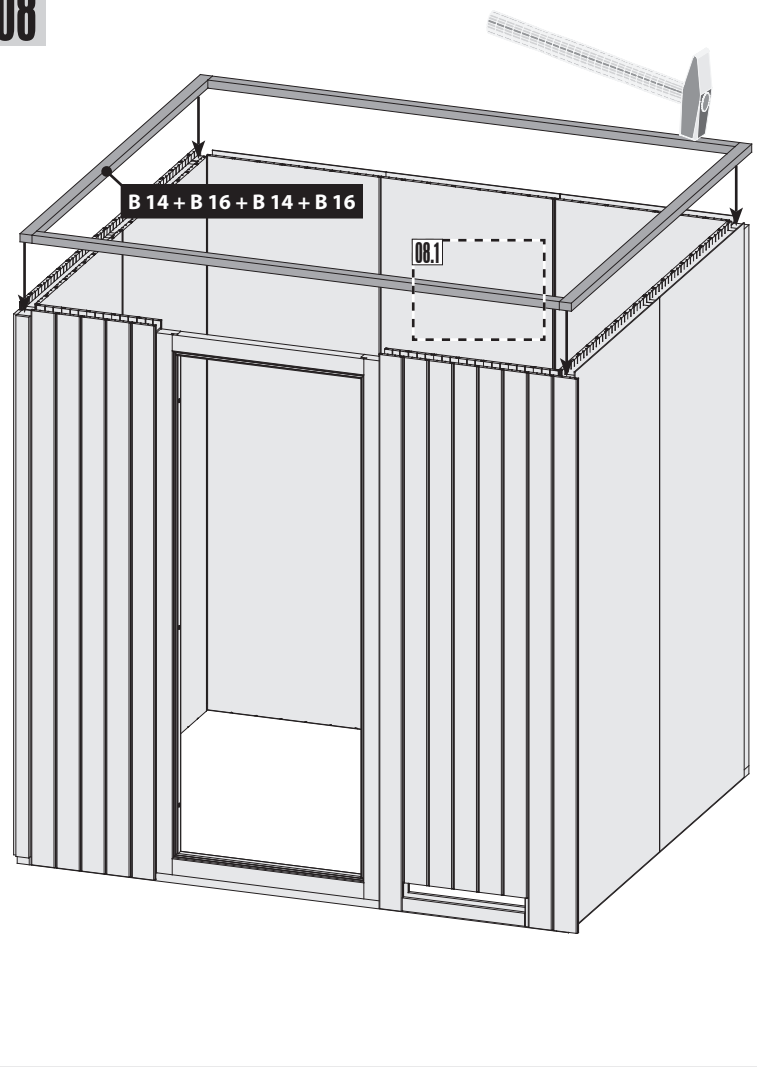

08.1

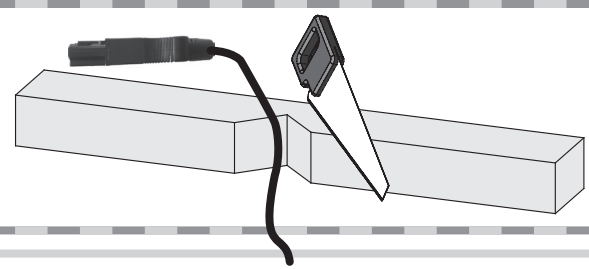

10

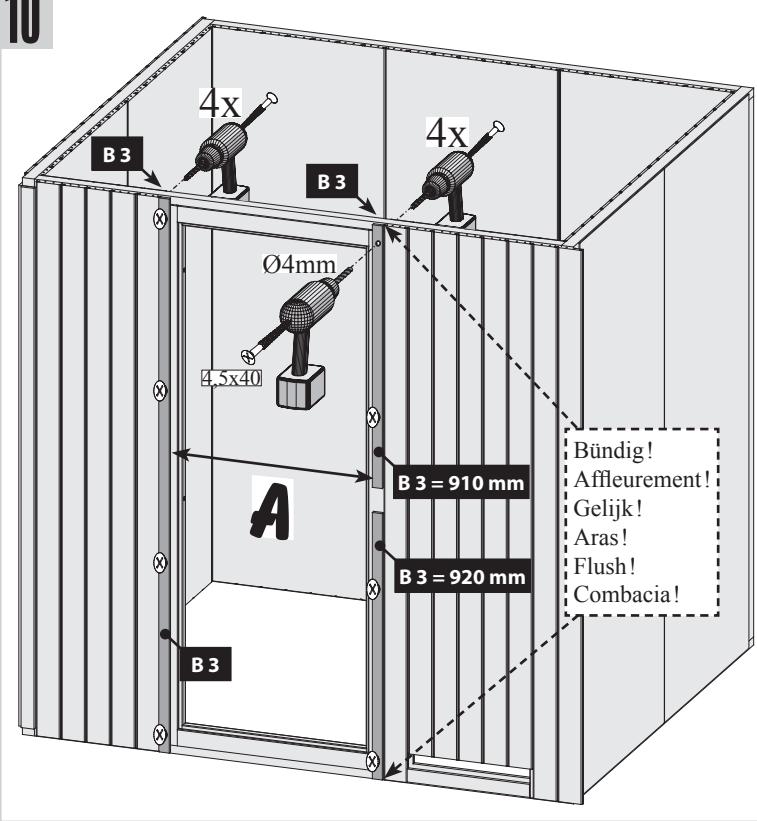

09 1x

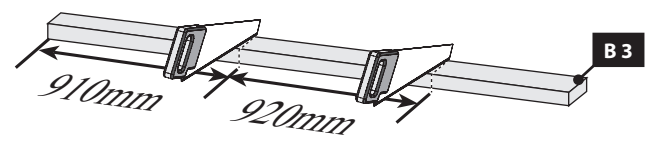

11 4x

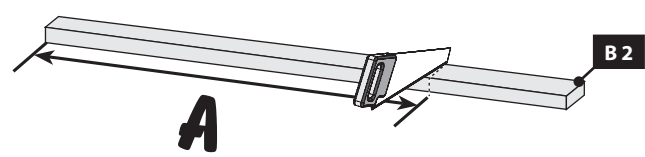

12

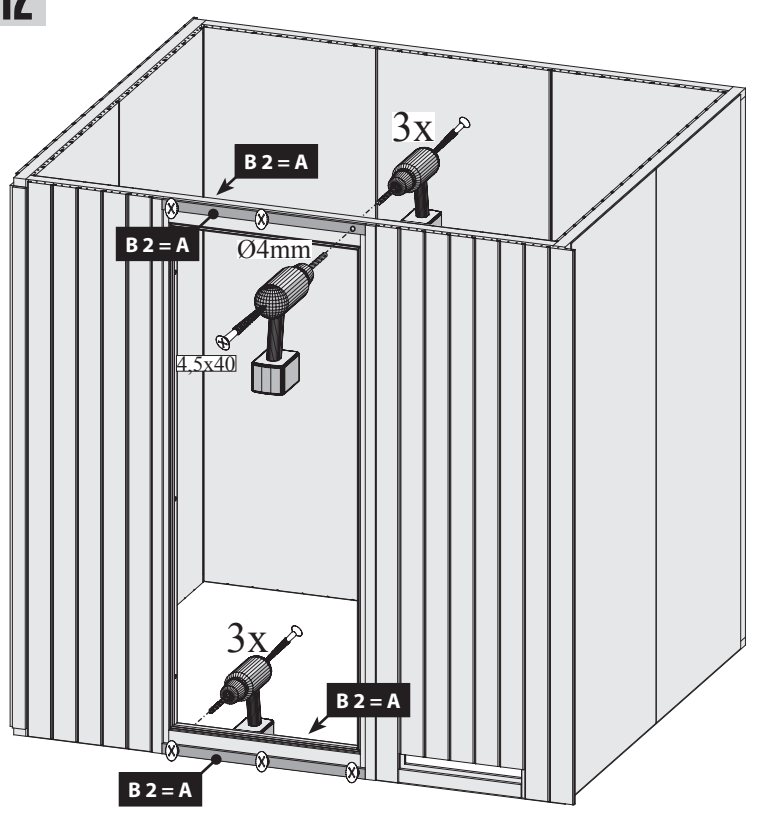

13

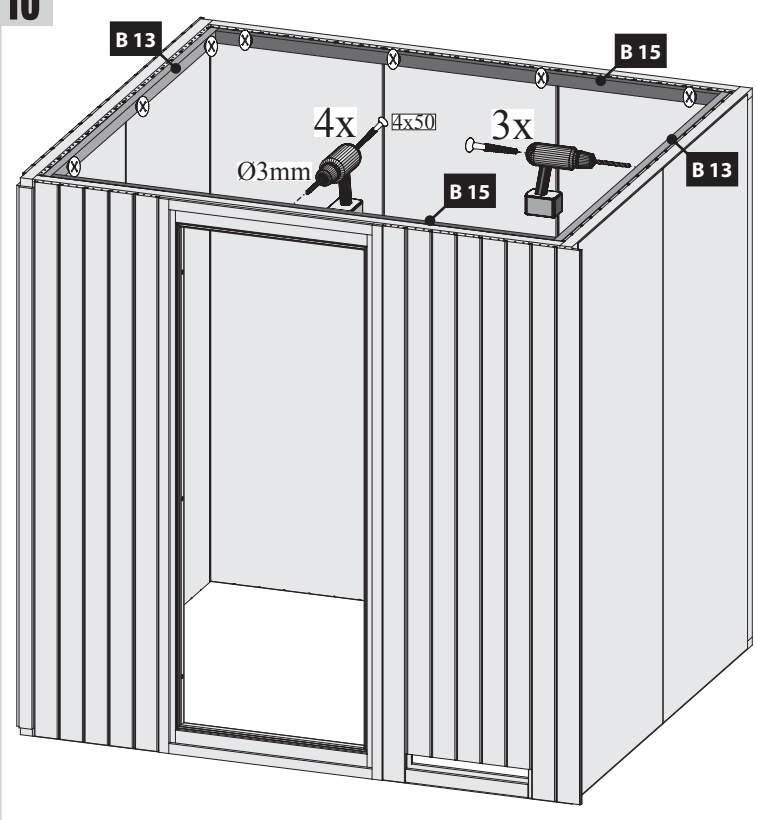

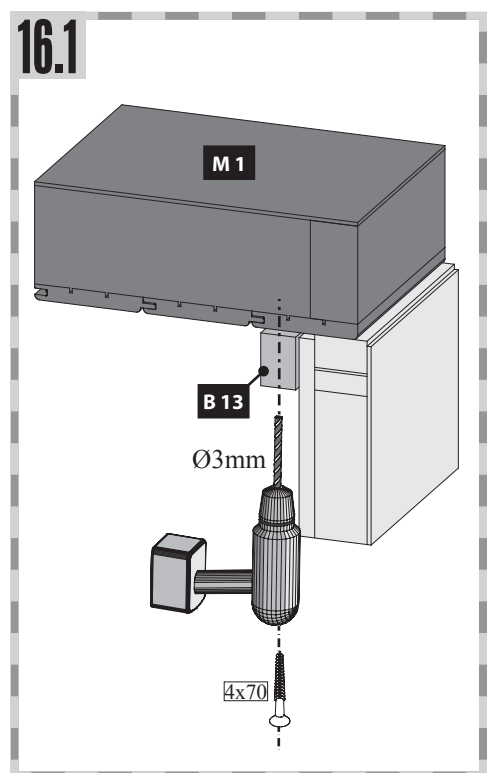
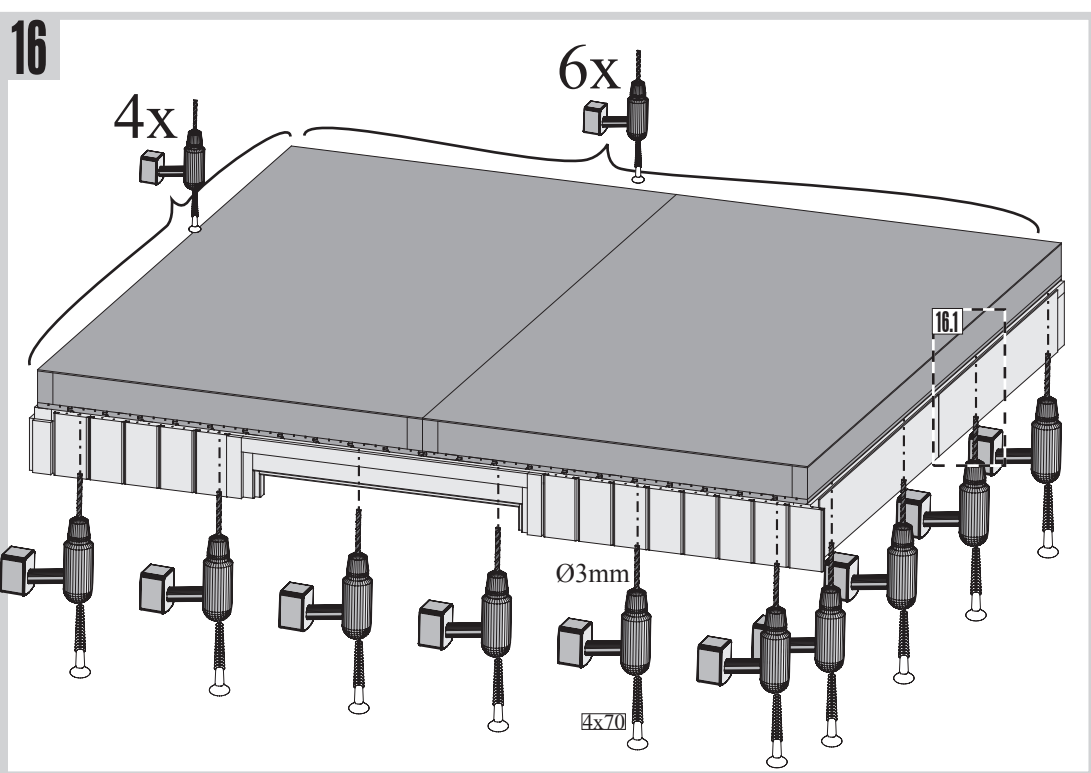
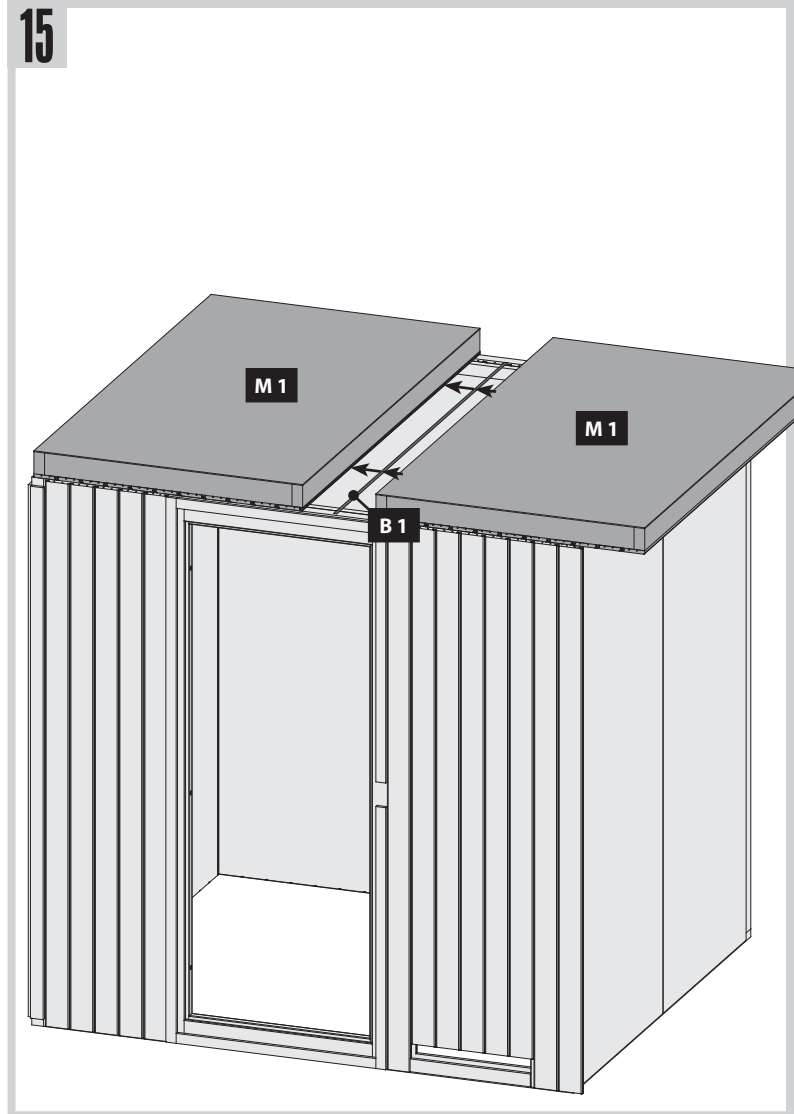
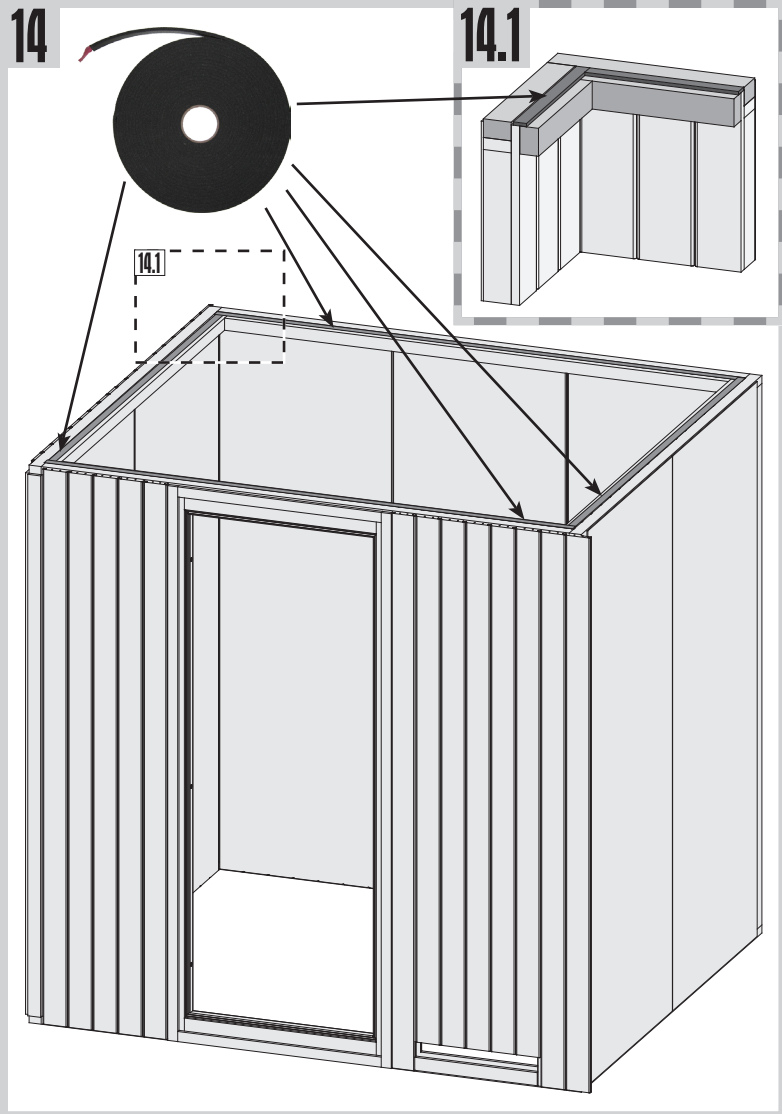

17

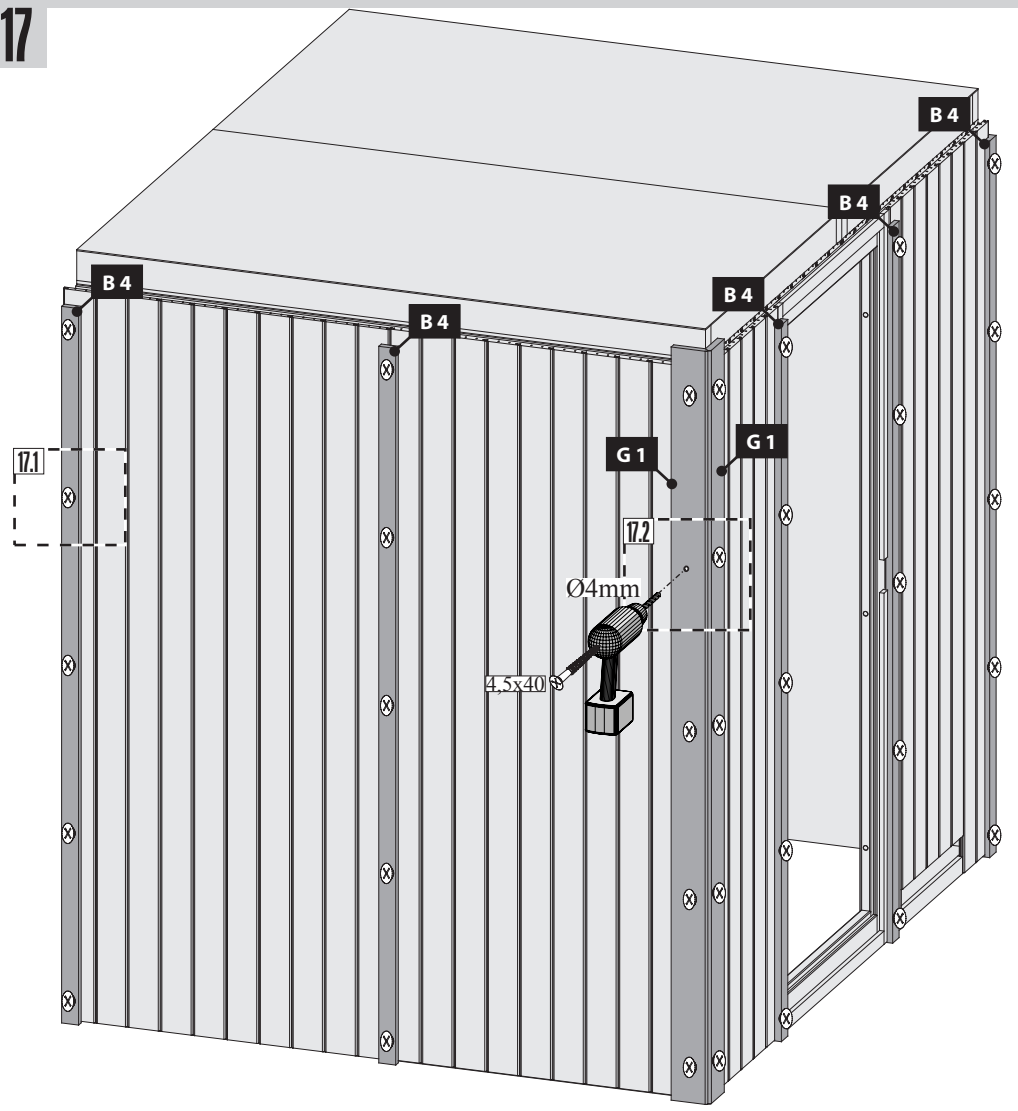

17.1

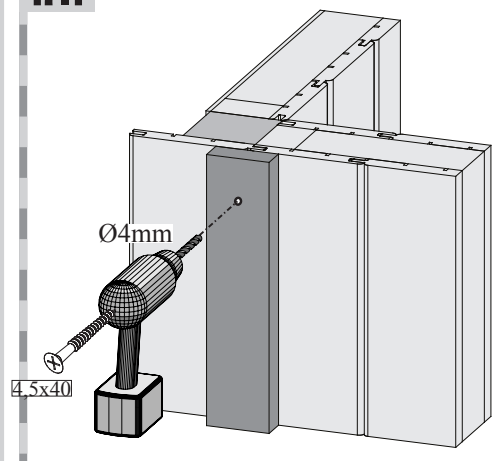

17.2

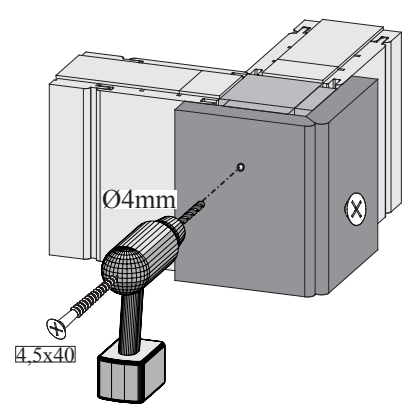

18

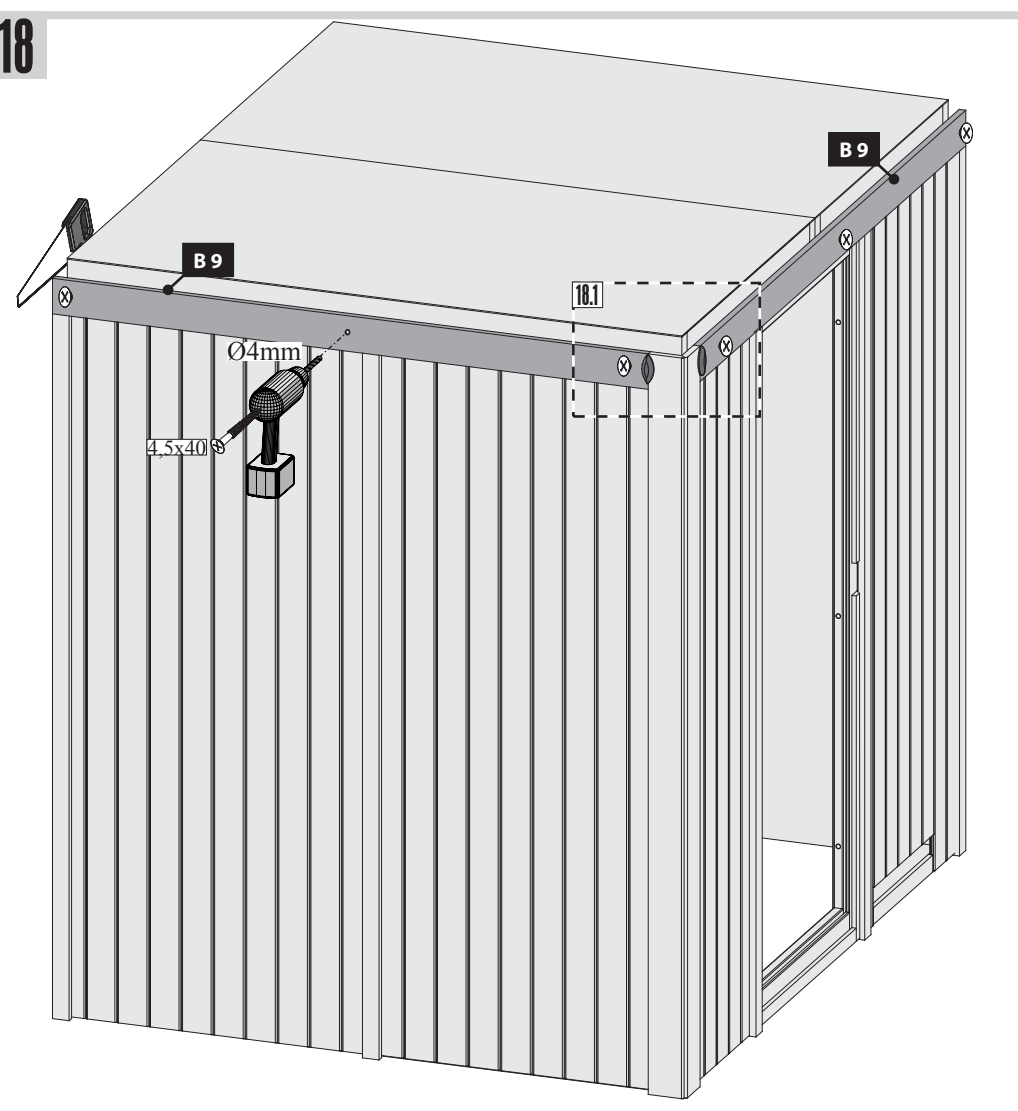

18.1

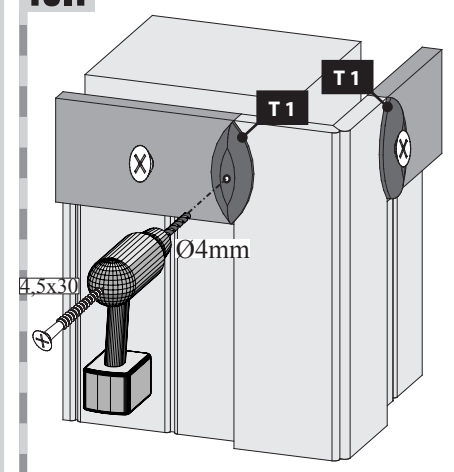



19

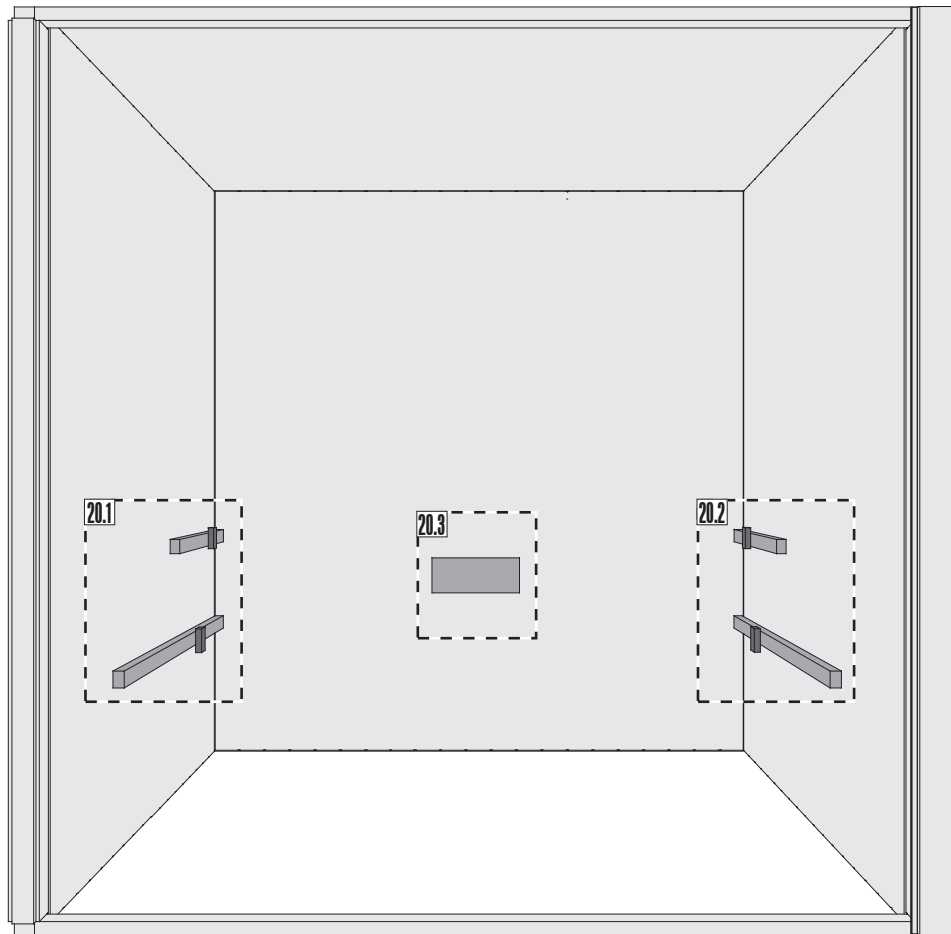



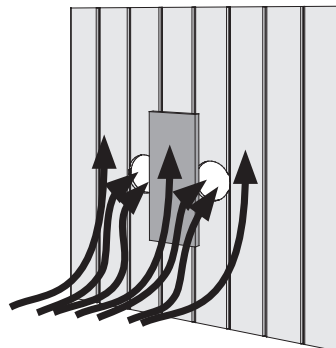
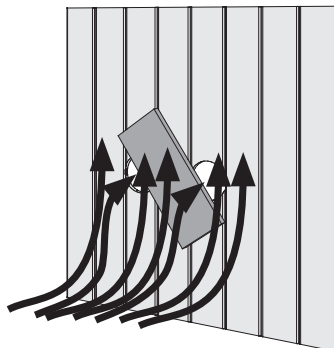
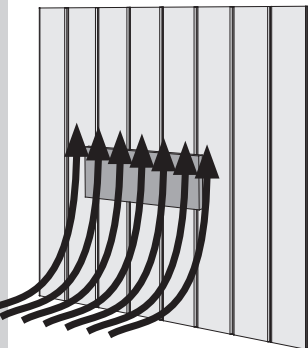
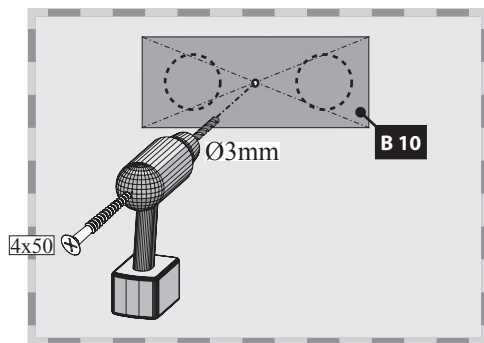

20.3





 Hier ist die Funktionsweise des Brettes abgebildet. Regeln Sie damit die Abluft nach Ihren eigenen Wünschen.

 Hier is de werking van het plankje afgebeeld. Regel daarmee de luchtafvoer naar eigen wens.

 Ceci représente le mode de fonctionnement de la planche. Avec elle, réglez l'écoulement de l'air selon vos désirs.

 Aquí está representada la forma de funcionamiento de la tabla. Regule con ello el aire de salida según sus propios deseos.

 This figure shows the functional principle of the board. Regulate the exhaust air according to your own wishes.

 Viene illustrato il principio di funzionamento della tavoletta di regolazione della ventilazione. Con essa si può regolare a piacere la ventilazione.

20.1-1

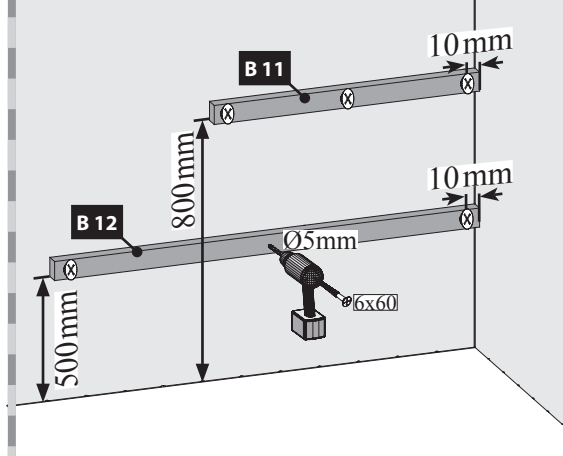

20.1-2

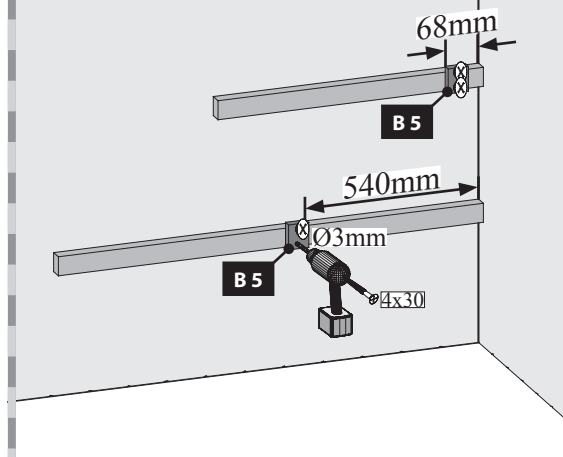

20.2-1

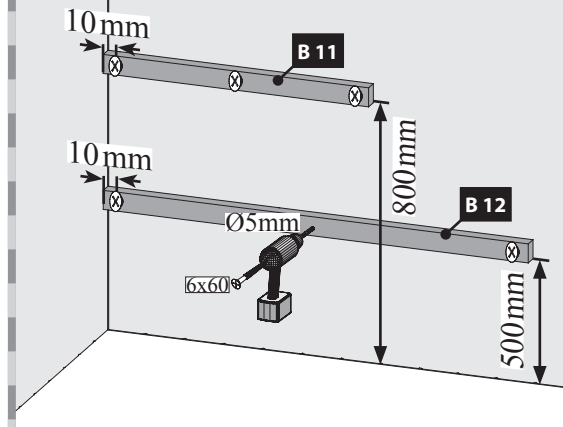

20.2-2

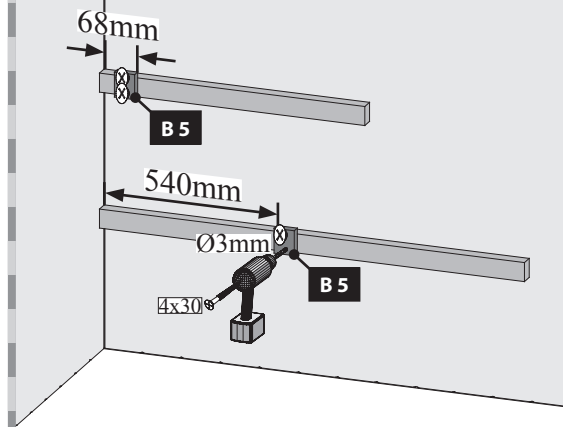

21 2x

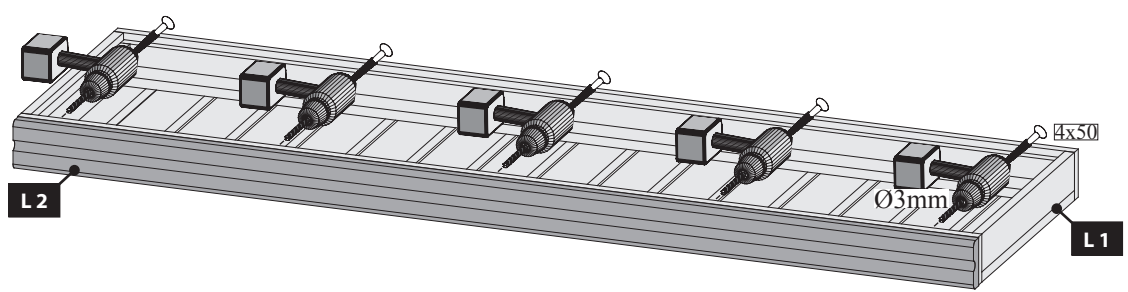
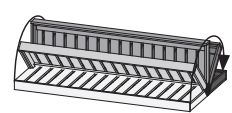

22 2x

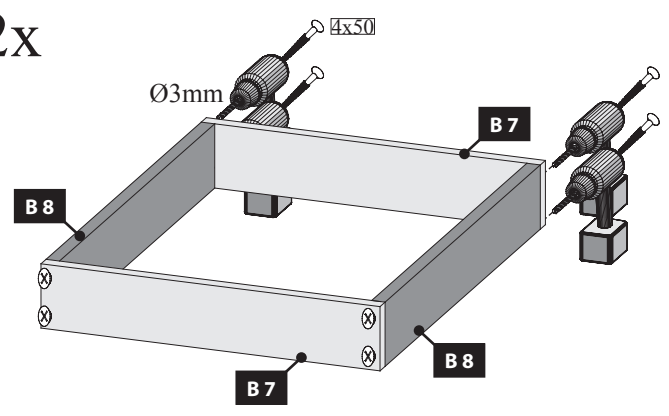

23

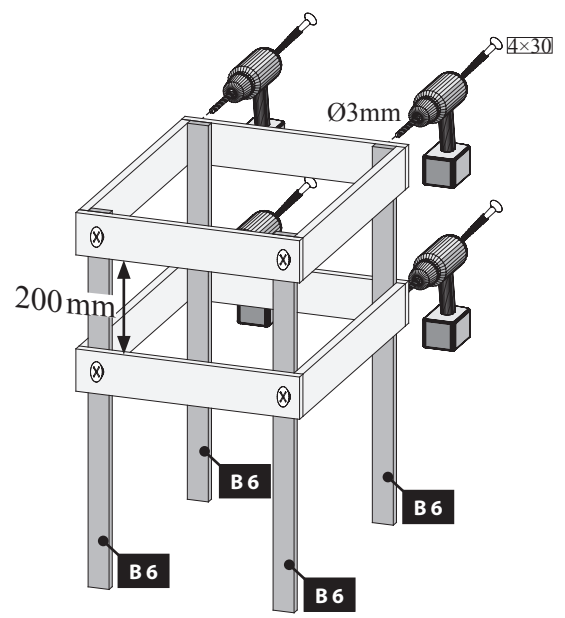

24

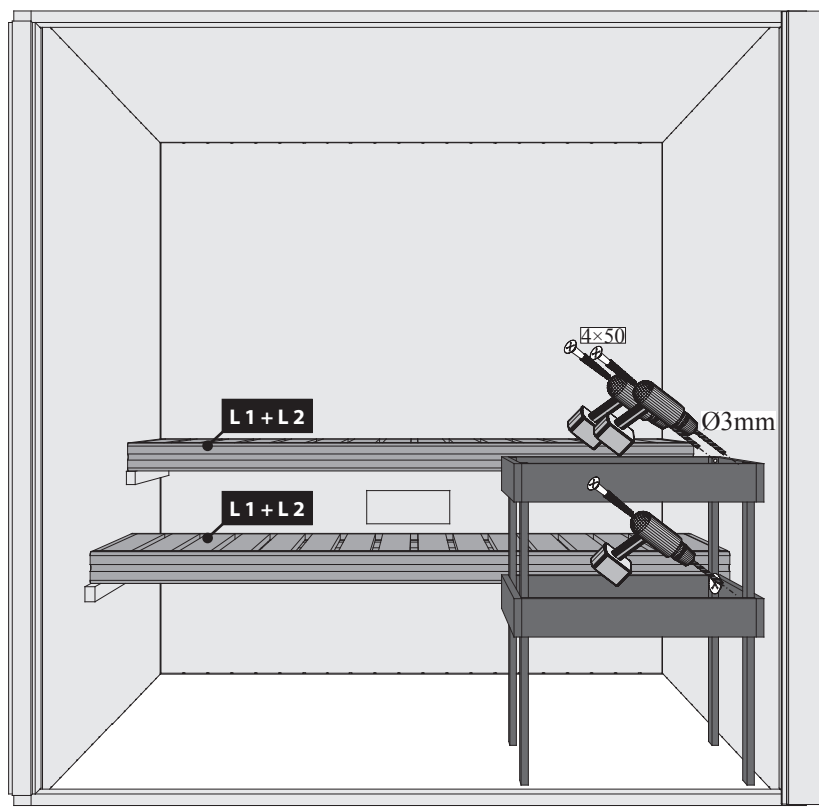

25

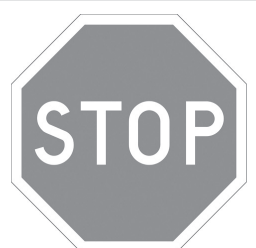
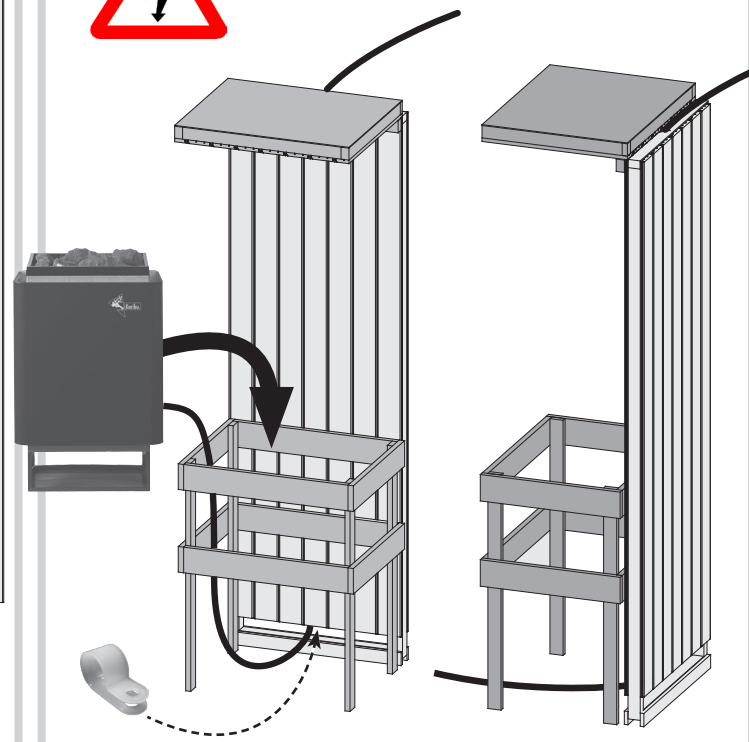

Einbau Saunatür

Installation de la porte de sauna

Installation of sauna door

Installatie van saunadeur

Montaje de la puerta de sauna

Porta Sauna Costruito

 Einbau Saunatür

 Installation of sauna door

 Montaje de la puerta de sauna

 Installation de la porte de sauna

 Installatie van saunadeur

 Porta Sauna Costruito

01

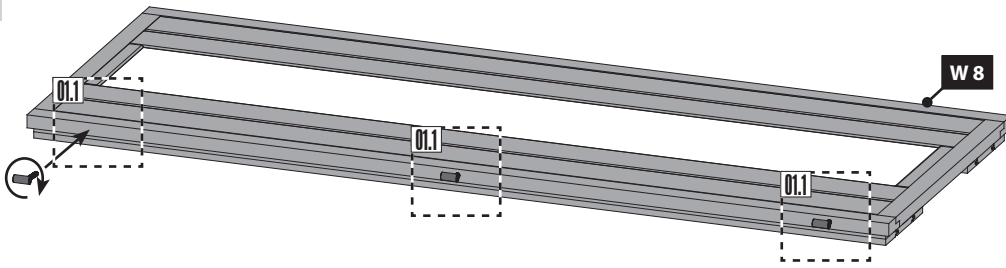

01.1

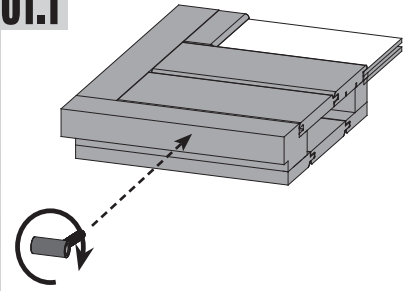

02

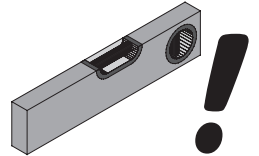
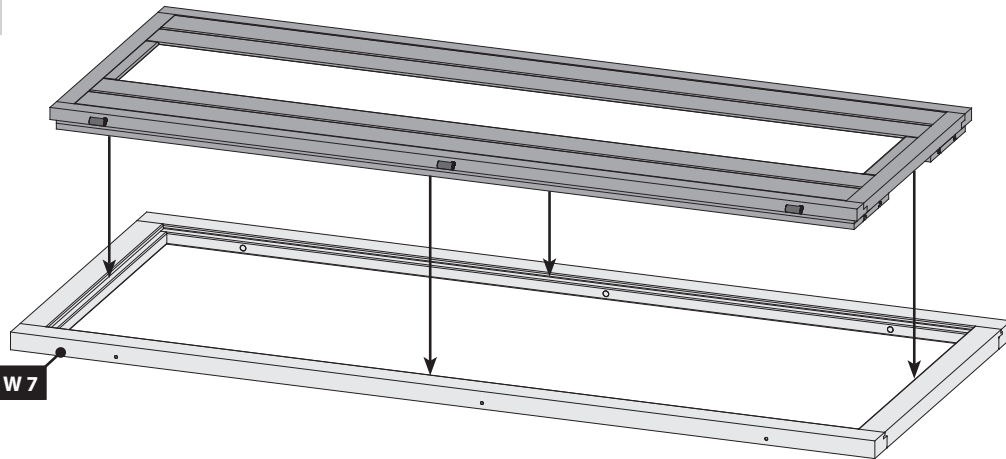

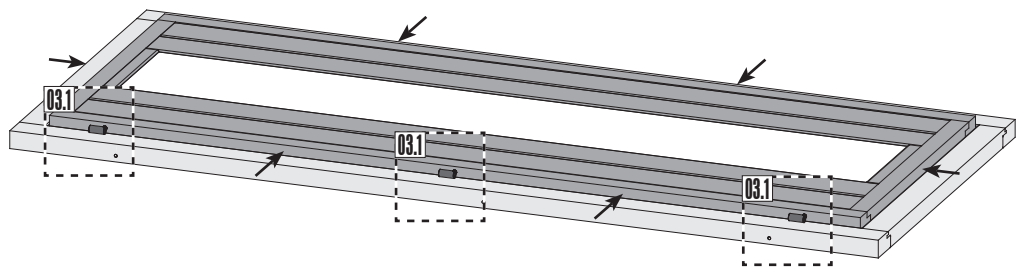

03



 Das Saunatürglas im Türrahmen ausrichten!

 Bien aligner le verre à vitre!

 To start building up the door you need to center the glass in the wooden frame!

 Plaats het glas van de sauna deur in het midden van het kozijn!

 ¡Centrar la puerta de cristal dentro del marco!

 Allineare il vetro dello sportello sauna al telaio della porta!

03.1-1

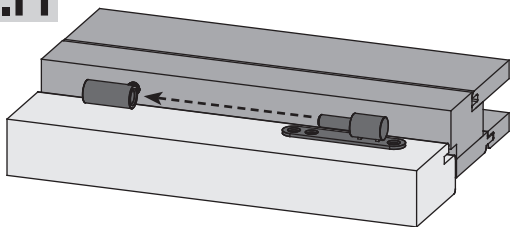

03.1-2

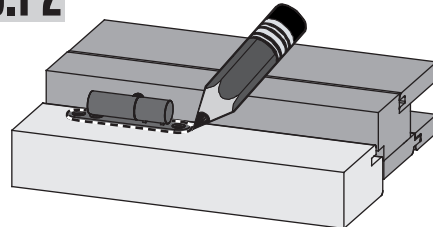

04

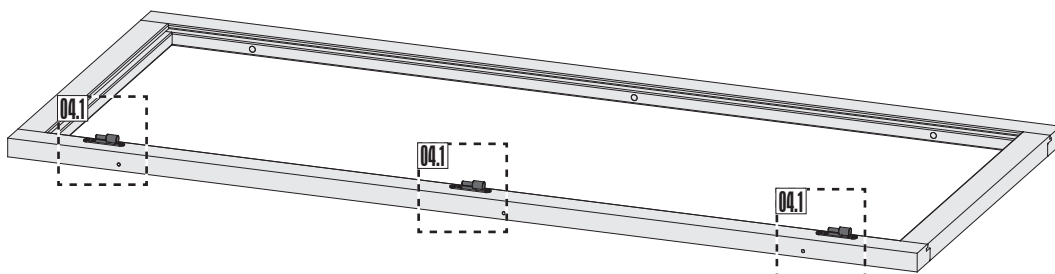

04.1

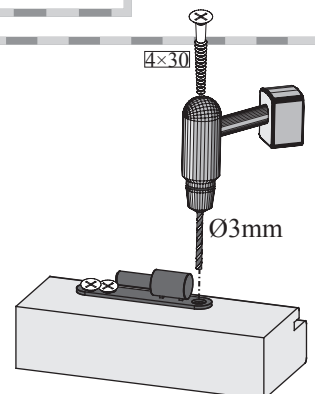

05

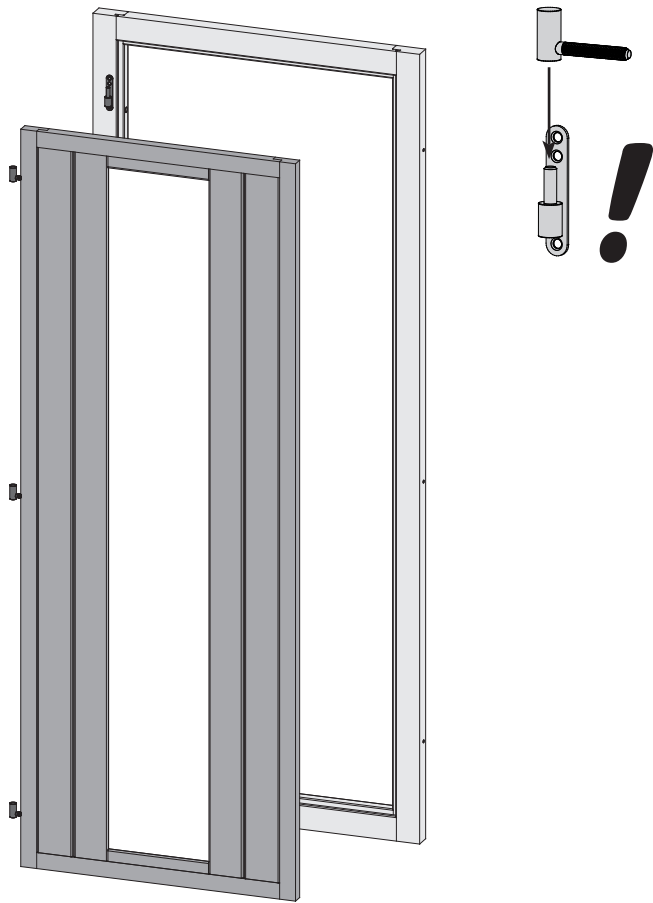

06

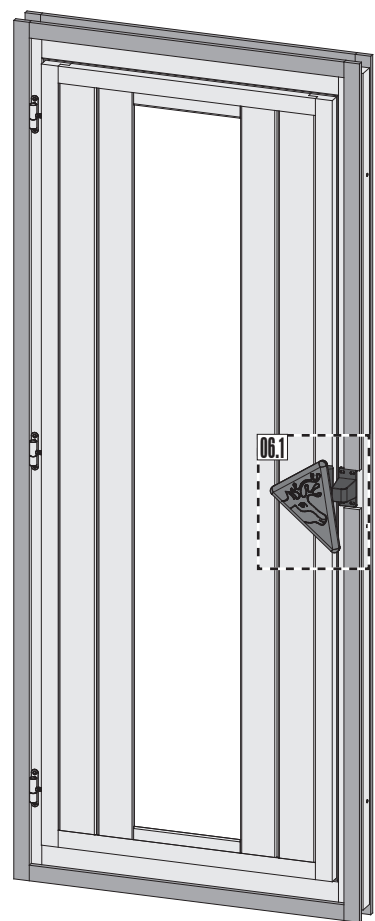

06.1-1

Bündig!
Affleurement!
Gelijk!
Aras!
Flush!
Combacia!

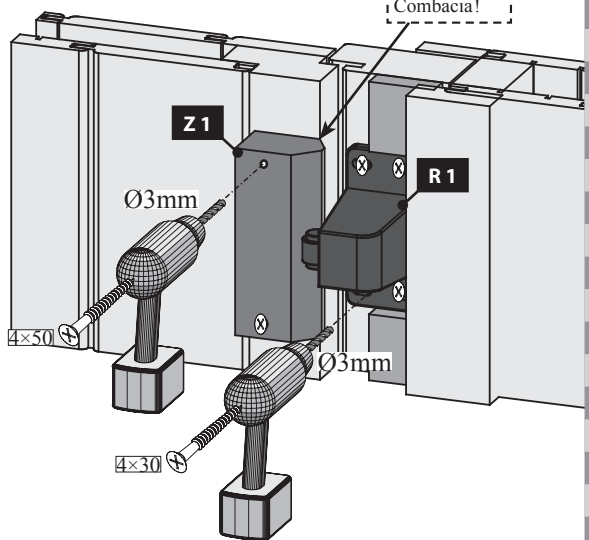

Bündig!
Affleurement!
Gelijk!
Aras!
Flush!
Combacia!

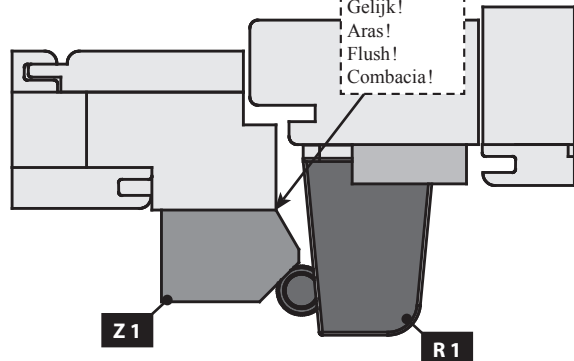

06.1-2

